

Planetary Stand Mixer

Model: CA-MX10C



- *It is a specially structured mixer with a powerful 3 - speed motor; planetary mixers are gear - driven, easy to operate and clean, and they have high efficiency.*
- *Durable 10 qt. stainless steel bowl; wire bowl guard for added safety.*
- *The standard accessories of mixers are wire whip, beater and hook.*
- *Easy to use with simple on / off buttons and manually operated bowl lift.*
- *It is made of aluminum. It can be placed both on the table and floor.*

Planetary Stand Mixer

Model: CA-MX10C

•ETL Certified For Safety & Sanitation



MODEL	VOLTS	HERTZ	PHASE	POWER	CAPACITY	DRY DOUGH CAPACITY	DRY CAPACITY	NEMA PLUG	NET WEIGHT	GROSS WEIGHT	EXTERNAL DIMENSION	SHIPPING DIMENSIONS
CA-MX10C	110V	60Hz	1PH	750W	10Qt.	4.4 lbs	7.1 lbs	5-15P	79 lbs	88 lbs	15 3/8" x 15 3/8" x 24"	19 9/16" x 18 7/16" x 28"

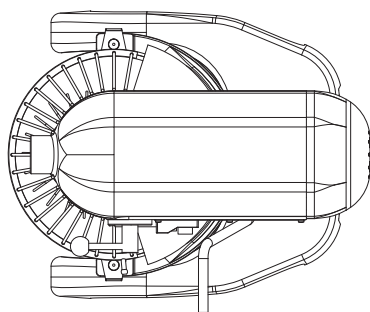
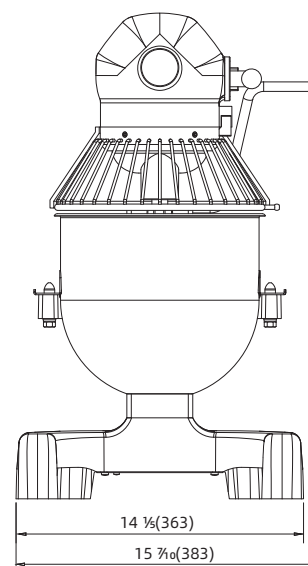
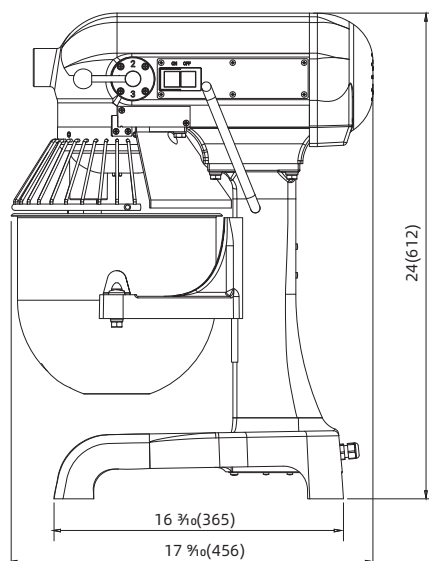

1 YEAR PARTS WARRANTY (NOT FOR RESIDENTIAL USE)

