

ChefAsst

www.chefasstusa.com

Project name : _____

Location : _____

Item# : _____ QTY : _____

Model# : _____

Planetary Stand Mixer

Model:CA-MX20B



- *It is a specially structured mixer with a powerful 3 - speed motor; planetary mixers are gear - driven, easy to operate and clean, and they have high efficiency.*
- *Durable 20 qt. stainless steel bowl; wire bowl guard for added safety.*
- *The standard accessories of mixers are wire whip, beater and hook.*
- *Easy to use with simple on / off buttons and manually operated bowl lift.*
- *It is made of aluminum. It can be placed both on the table and floor.*

Toll Free: +1 (800) 373-8699
polarman@chefmindgroup.com
Address: 1189S Jellick Ave,
City of Industry, CA 91748



Planetary Stand Mixer

Model:CA-MX20B

•ETL Certified For Safety & Sanitation



MODEL	VOLTS	HERTZ	PHASE	POWER	CAPACITY	DRY DOUGH CAPACITY	DRY CAPACITY	NEMA PLUG	NET WEIGHT	GROSS WEIGHT	EXTERNAL DIMENSION	SHIPPING DIMENSIONS
CA-MX20B	110V	60Hz	1PH	1100W	20Qt.	11 lbs	17.6 lbs	5-15P	141 lbs	176 lbs	21 7/10" x 22" x 31 3/10"	24 1/2" x 23 1/5" x 35"

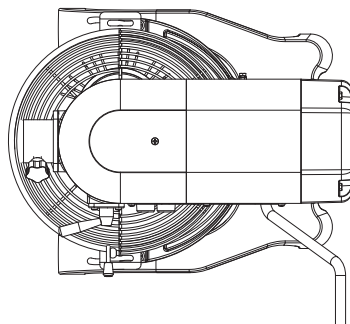
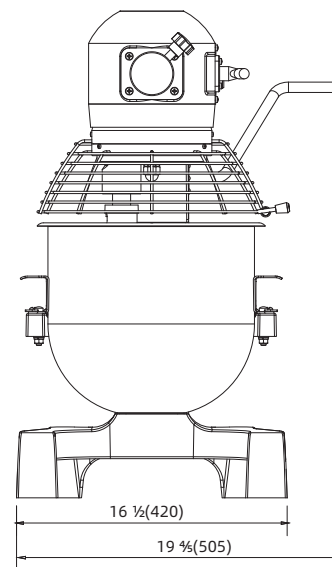
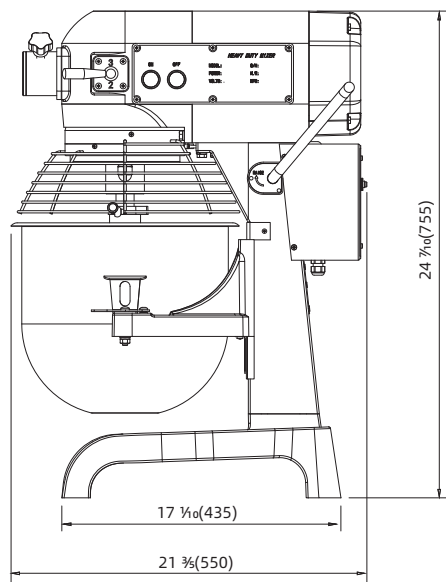

1 YEAR PARTS WARRANTY (NOT FOR RESIDENTIAL USE)



CHEFMIND GROUP INC.

SPECIFICATIONS SUBJECT TO CHANGE WITHOUT NOTICE