

# ChefAsst

www.chefasstusa.com

Project name : \_\_\_\_\_

Location : \_\_\_\_\_

Item# : \_\_\_\_\_ QTY : \_\_\_\_\_

Model# : \_\_\_\_\_

## Planetary Stand Mixer

### Model:CA-MX20C



- It is a specially structured mixer with a powerful 3 - speed motor; planetary mixers are gear - driven, easy to operate and clean, and they have high efficiency.
- Durable 20 qt. stainless steel bowl; wire bowl guard for added safety.
- The standard accessories of mixers are wire whip, beater and hook.
- Easy to use with simple on / off buttons and manually operated bowl lift.
- It is made of aluminum. It can be placed both on the table and floor.

Toll Free: +1 (800) 373-8699  
polarman@chefmindgroup.com  
Address: 1189S Jellick Ave,  
City of Industry, CA 91748



# Planetary Stand Mixer

## Model:CA-MX20C

**•ETL Certified For Safety & Sanitation**



MODEL	VOLTS	HERTZ	PHASE	POWER	CAPACITY	DRY DOUGH CAPACITY	DRY CAPACITY	NEMA PLUG	NET WEIGHT	GROSS WEIGHT	EXTERNAL DIMENSION	SHIPPING DIMENSIONS
CA-MX20C	110V	60Hz	1PH	1100W	20Qt.	11 lbs	17.6 lbs	5-15P	212 lbs	247 lbs	21 7/10" x 22" x 31 3/10"	24 1/2" x 23 1/2" x 35"

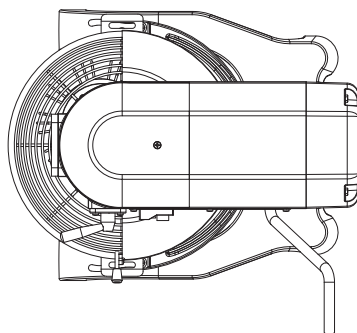
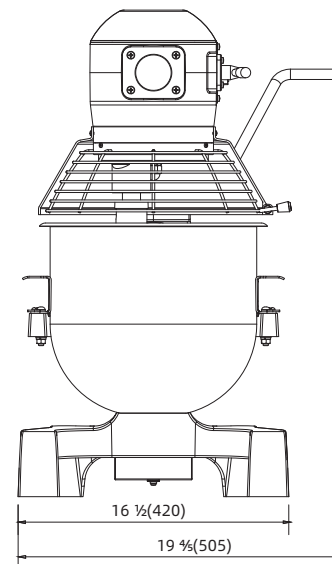
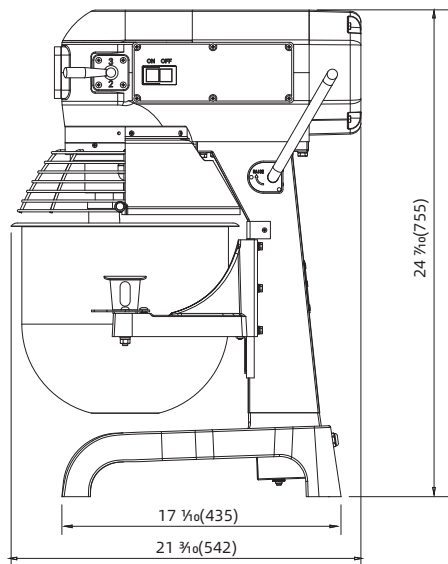

**1 YEAR PARTS WARRANTY (NOT FOR RESIDENTIAL USE)**



**CHEFMIND GROUP INC.**

SPECIFICATIONS SUBJECT TO CHANGE WITHOUT NOTICE