

# ChefAsst

www.chefasstusa.com

Project name : \_\_\_\_\_

Location : \_\_\_\_\_

Item# : \_\_\_\_\_ QTY : \_\_\_\_\_

Model# : \_\_\_\_\_

## Planetary Stand Mixer

### Model:CA-MX30B



- *It is a specially structured mixer with a powerful 3 - speed motor; planetary mixers are gear - driven, easy to operate and clean, and they have high efficiency.*
- *Durable 30 qt. stainless steel bowl; wire bowl guard for added safety.*
- *The standard accessories of mixers are wire whip, beater and hook.*
- *Easy to use with simple on / off buttons and manually operated bowl lift.*
- *It is made of aluminum. It can be placed both on the table and floor.*

**Toll Free: +1 (800) 373-8699**  
**polarman@chefmindgroup.com**  
Address: 1189S Jellick Ave,  
City of Industry, CA 91748



# Planetary Stand Mixer

## Model:CA-MX30B

**•ETL Certified For Safety & Sanitation**



MODEL	VOLTS	HERTZ	PHASE	POWER	CAPACITY	DRY DOUGH CAPACITY	DRY CAPACITY	NEMA PLUG	NET WEIGHT	GROSS WEIGHT	EXTERNAL DIMENSION	SHIPPING DIMENSIONS
CA-MX30B	110V	60Hz	1PH	1500W	30Qt.	17 lbs	25 lbs	5-15P	375 lbs	397lbs	22 1/8" x 24" x 45"	28" x 26 3/8" x 50"

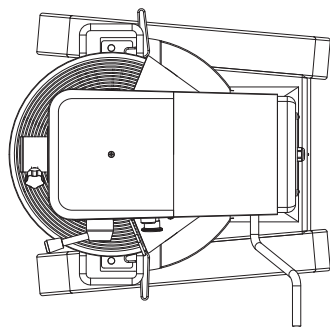
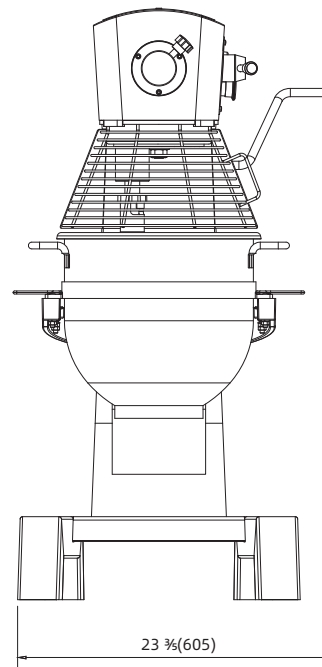
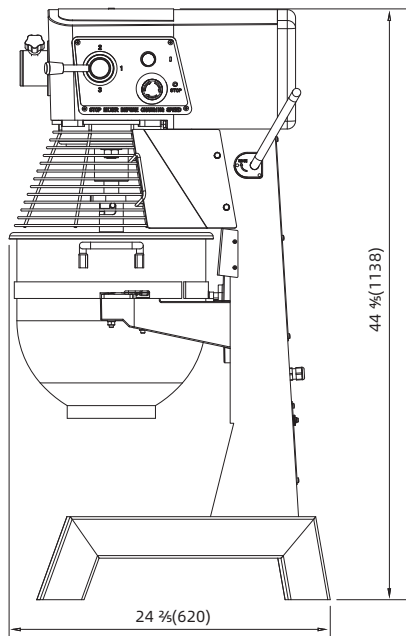

**1 YEAR PARTS WARRANTY (NOT FOR RESIDENTIAL USE)**



**CHEFMIND GROUP INC.**

SPECIFICATIONS SUBJECT TO CHANGE WITHOUT NOTICE