

# ChefAsst

www.chefasstusa.com

Project name : \_\_\_\_\_

Location : \_\_\_\_\_

Item# : \_\_\_\_\_ QTY : \_\_\_\_\_

Model# : \_\_\_\_\_

## Bowl Lift Countertop Mixer

### Model:CA-MXN7C



- *This is a powerful countertop mixer designed for small-batch production in restaurant kitchens or professional bakeries.*
- *The mixer features stepless speed control (with two-speed functionality), a powerful 0.36-horsepower motor, and a removable safety guard.*
- *304 stainless steel bowl (thickness: 1.0 mm).*
- *Micro switches (lift-off safety switch; bowl lock switch).*
- *High speed: For preparing eggwhites (soufflé, meringue, etc.), sauces (mayonnaise, etc.).*
- *Middle speed: For mixing soft dough, meat, cream, etc.*
- *Low speed: For mixing heavy dough, bread, pastry, etc.*

**Toll Free: +1 (800) 373-8699**  
**polarman@chefmindgroup.com**  
Address: 1189S Jellick Ave,  
City of Industry, CA 91748



# Bowl Lift Countertop Mixer

## Model: CA-MXN7C

**•ETL Certified For Safety & Sanitation**



MODEL	VOLTS	HERTZ	PHASE	POWER	CAPACITY	DRY DOUGH CAPACITY	DRY CAPACITY	NEMA PLUG	NET WEIGHT	GROSS WEIGHT	EXTERNAL DIMENSION	SHIPPING DIMENSIONS
CA-MXN7C	110V	60Hz	1PH	250W	7Qt.	3.3 lbs	5.3 lbs	5-15P	33 lbs	38 lbs	16 1/10" x 9 1/10" x 16 1/2"	19 1/10" x 12 3/8" x 19 7/10"

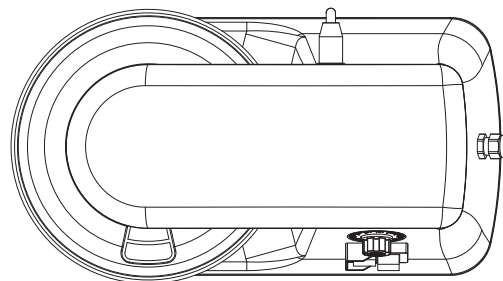
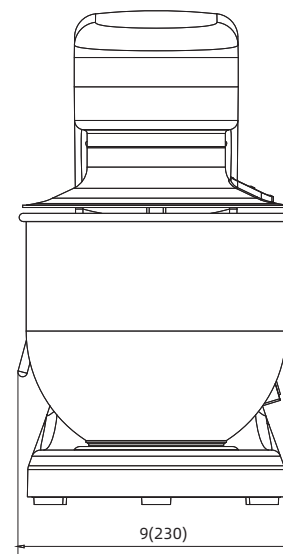
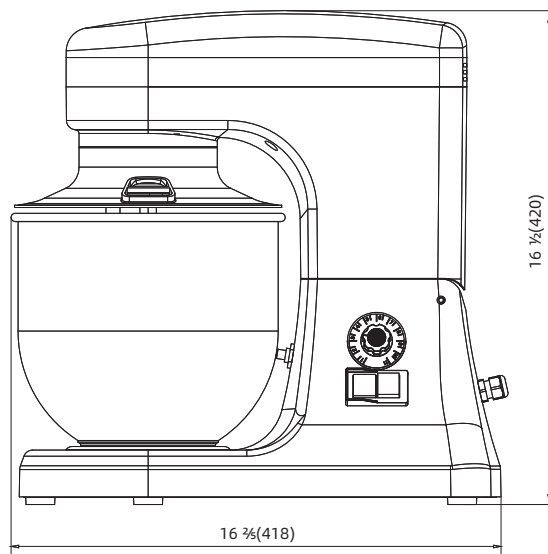

**1 YEAR PARTS WARRANTY (NOT FOR RESIDENTIAL USE)**



**CHEFMIND GROUP INC.**

SPECIFICATIONS SUBJECT TO CHANGE WITHOUT NOTICE