

Flamaster

www.flamasterusa.com

Project name: _____

Location: _____

Item#: _____ QTY: _____

Model#: _____

Electric Hot Plate

Model: FLM-EHP15



- *Electric hot plate are a perfect addition to any food service operation.*
- *2 kW round plate elements with easy-to-clean flat surface.*
- *Provides a solid flat surface for fast, even heating.*
- *Round plates are 9" (229) diameter for maximum pan contact.*
- *Infinite heat controls for maximum cooking flexibility.*
- *Available in 15" single and dual plates, 24", 36" widths.*
- *15", 24" and 36" widths.*
- *Stainless steel front, top and sides for cleanability and professional look.*
- *Infinite heat controls for maximum cooking flexibility.*
- *Heavy-duty metal knobs.*
- *4" (102 mm) adjustable stainless steel non-skid feet.*
- *This appliance is manufactured for commercial installation only, not intended for home use.*
- *For supply connections use copper wire only, suitable for at least 90°C (194°F).*
- *An adequate ventilation system is required for Commercial Cooking Equipment.*
- *Require a 1" clearance at both side and rear adjacent to combustible construction.*

Toll Free: +1(800)373-8699
flamaster@chefmindgroup.com
Address: 1189S Jellick Ave,
City of Industry, CA 91748

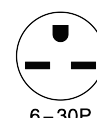

Electric Hot Plate

Model: FLM-EHP15

•ETL c/us and Sanitation Listed

MODEL	VOLTS PHASE	WATTS	OVERALL DIMENSIONS	NET WEIGHT	SHIPPING DIMENSIONS	Shipping Weight
FLM-EHP15	208V/1P	4,000	15 X 29 ³ / ₈ X 14 ¹ / ₂	47 lbs.(21.5kg)	18 ¹ / ₁₀ X 34 ⁷ / ₁₀ X 19 ³ / ₁₀	70 lbs.(32 kg)

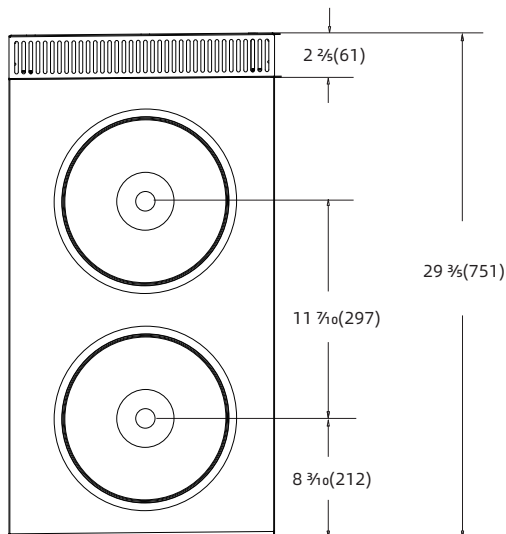
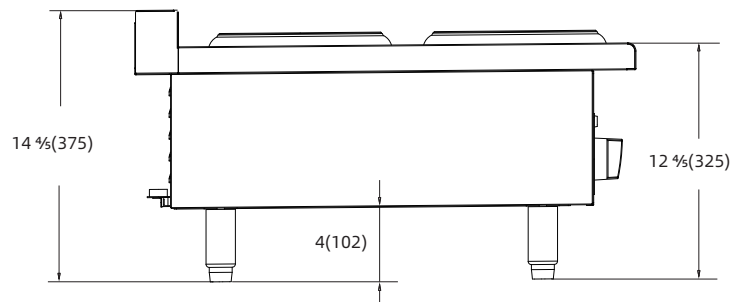
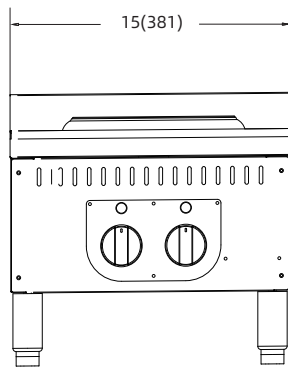

1 YEAR PARTS WARRANTY (NOT FOR RESIDENTIAL USE)



CHEFMIND GROUP INC.

SPECIFICATIONS SUBJECT TO CHANGE WITHOUT NOTICE