

# **Flamaster**

## **INSTALLATION & OPERATION MANUAL** **Salamander Broiler**

**Model: FLM-SM36**

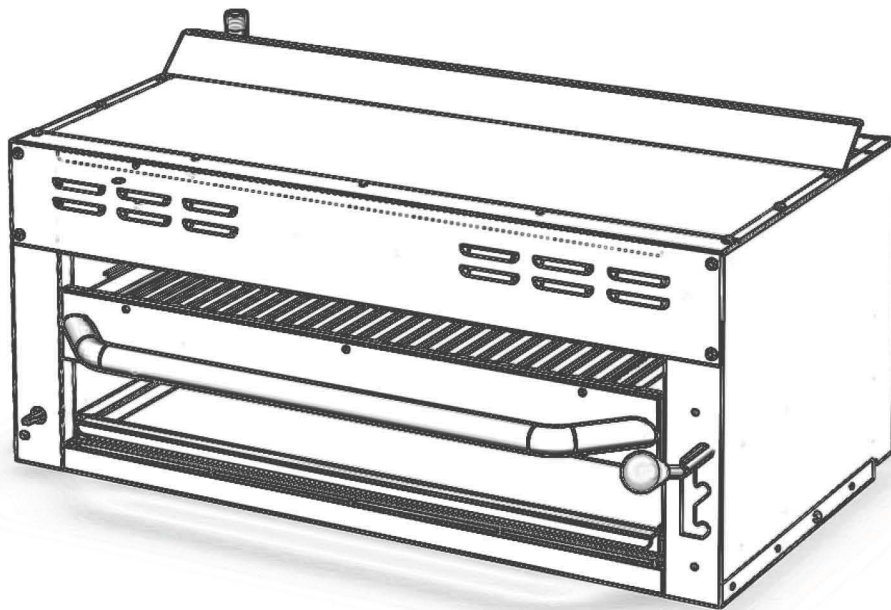

**!** WARNING: IMPROPER INSTALLATION, ADJUSTMENT, ALTERATION, SERVICE, MAINTENANCE CAN CAUSE PROPERTY DAMAGE, INJURY OR DEATH. READ THE INSTALLATION, OPERATING AND MAINTENANCE INSTRUCTIONS THOROUGHLY BEFORE INSTALLING OR SERVICING THIS EQUIPMENT.

Please call the Service Department and ask for contact information for your local service company.

## **IMPORTANT FOR YOUR SAFETY**

**THIS MANUAL HAS BEEN PREPARED FOR PERSONNEL QUALIFIED TO INSTALL GAS EQUIPMENT, WHO SHOULD PERFORM THE INITIAL FIELD START-UP AND ADJUSTMENTS OF THE EQUIPMENT COVERED BY THIS MANUAL.**

**POST IN A PROMINENT LOCATION THE INSTRUCTIONS TO BE FOLLOWED IN THE EVENT THE SMELL OF GAS IS DETECTED. THIS INFORMATION CAN BE OBTAINED FROM THE LOCAL GAS SUPPLIER.**

### **IMPORTANT**

**IN THE EVENT A GAS ODOR IS DETECTED, SHUT DOWN UNITS AT MAIN SHUT OFF VALVE AND CONTACT THE LOCAL GAS COMPANY OR GAS SUPPLIER FOR SERVICE.**

### **FOR YOUR SAFETY**

**DO NOT STORE OR USE GASOLINE OR OTHER FLAMMABLE VAPORS OR LIQUIDS IN THE VICINITY OF THIS OR ANY OTHER APPLIANCE.**



**WARNING: IMPROPER INSTALLATION, ADJUSTMENT, ALTERATION, SERVICE OR MAINTENANCE CAN CAUSE PROPERTY DAMAGE, INJURY OR DEATH. READ THE INSTALLATION, OPERATING AND MAINTENANCE INSTRUCTIONS THOROUGHLY BEFORE INSTALLING OR SERVICING THIS EQUIPMENT.**

# INSTALLATION, OPERATION AND CARE OF SALAMANDER BROILERS

## GENERAL

Salamander Broilers are produced with quality workmanship and materials. Proper installation, usage, and maintenance of your broiler will result in many years of satisfactory performance.

It is suggested that you thoroughly read this entire manual and carefully follow all of the instructions provided.

Product parameter:

Model <b>CP-SM-36</b>	BTU	Orifice size		Regulator pressure	
		Nat.	LP	Nat.	LP
36" Salamander	<b>32,000</b>	#31	#52	5"WC	10"WC

THIS APPLIANCE IS EQUIPPED FOR NATURAL GAS.

For Natural gas when equipped with No. #31 drill size orifice.

For LP gas when equipped with No.#52 drill size orifice.

For conversion to LP gas orifice see instruction plate on the appliance, see Page 11.

## INSTALLATION

Before installing, verify that the type of gas supply (natural or propane) agrees with the specifications on the rating plate located underneath the broiler rack drip tray. If the supply and equipment requirements do not agree, do not proceed with the installation. Contact your dealer immediately.

### UNPACKING

Immediately after unpacking, check for possible shipping damage. If the broiler is found to be damaged, save the packaging material and contact the carrier within 15 days of delivery.

Before installing, verify that the type of gas (natural or propane) and the clearance dimensions (see below) agree with the specifications on the rating plate which is located under the crumb tray on the right side.

### LOCATION

The equipment area must be kept free and clear of combustible substances.

Minimum Clearance	Combustible Construction	Non-Combustible Construction
Rear	2"	0"
Sides	2"	0"
Bottom	0"	0"

The installation location must allow adequate clearances for servicing and proper operation.

A minimum front clearance of 24" is required.

Do not obstruct the flow of combustion and ventilation air. Adequate clearance for air openings into the combustion chamber must be provided. Make sure there is an adequate supply of air in the room to replace air taken out by the ventilating system. Do not permit fans to blow directly at the broiler. Avoid wall-type fans which create air cross currents with in the room. Avoid open windows next to the broiler. Maintain an 18" (46 cm) clearance from the top of the broiler flue vent to the filters of the hood venting system.

## INSTALLATION CODES AND STANDARDS

The broiler must be installed in accordance with:

In the United States of America:

1. State and local codes.

2. National Fuel Gas Code, ANSI-Z223.1/NFPA #54 (latest edition). This shall include but not be limited to: NFPA #54 Section 10.3.5.2 for Venting. Copies may be obtained from The American Gas Association Accredited Standards Committee Z223, @ 400N. Capital St. NW, Washington, DC 20001 or the Secretary Standards Council, NFP A,1 Batterymarch Park Quincy, MA 02169 -7471

NOTE: In the Commonwealth of Massachusetts

All gas appliances vented through a ventilation hood or exhaust system equipped with a damper or with a power means of exhaust shall comply with 248 CMR.

3. NFPA Standard # 96 Vapor Removal from Cooking Equipment , latest edition, available from the National Fire Protection Association, Batterymarch Park , Quincy, MA 02269. In Canada:

1. Local codes.

2. CAN/CSA-B 149.1 Natural Gas Installation (latest edition)

3. CAN/CSA-B 149.2 Propane Installation Code (latest edition), available from the Canadian Gas Association, 178 Rexdale Blvd., Etobicoke, Ontario, Canada M9W 1R3

The appliance and its individual shutoff valve must be disconnected from the gas supply piping system during any pressure testing of that system at test pressures in excess of 1/2psi(3.5kPa).

The appliance must be isolated from the gas supply piping system by closing its individual pressures equal to or less than 1/2 psi (3.5 kPa).

## GAS CONNECTIONS

Codes require that a gas shutoff valve be installed in the gas line ahead of the broiler.

NATURAL GAS: Standard orifices are set at 5" W .C. (Water Column). A pressure regulator is supplied and must be installed when the broiler is connected to the gas supply.

LP GAS: Standard orifices are set at 10" W .C. (Water Column). A pressure regulator is supplied and must be installed when the broiler is connected to the gas supply.

The gas supply line must be 3/4" or larger. If flexible or semi-rigid connections are used, the inside diameter must be the equivalent of 3/4" iron pipe or larger. All connections of the flexible and semi-rigid type must comply with all local and national requirements. Make sure gas piping is clean and free of dirt, piping compound, and obstructions.

**WARNING:** PRIOR TO LIGHTING, CHECK ALL JOINTS IN THE GAS SUPPLY LINE FOR LEAKS. USE SOAP AND WATER SOLUTION. DO NOT USE AN OPEN FLAME.

After piping has been checked for leaks, all piping receiving gas should be fully purged to remove air.

### GAS PRESSURE REGULATOR INSTALLATION

Gas regulator pressure is preset at 5" Water Column (W .C.) for natural gas, and 10" W .C. For propane gas. Minor adjustments may be required based on site specific gas pressure.

Install the regulator as close to the broiler on the gas supply line as possible. Make sure that the arrow on the underside of the regulator is oriented in the direction of gas flow to the broiler (**Fig. 1**) and the regulator is positioned with the vent plug and adjustment screw upright (**Fig. 2**). A recommended plumbing schematic is listed below only for Salamander units as a guide to the installer and it is in no way liable for plumbing installation (**Fig. 3**).

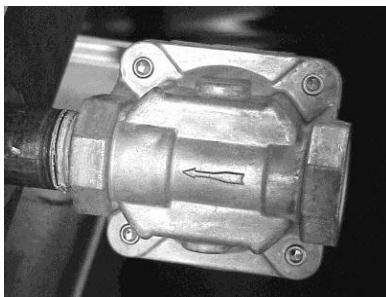

**Fig.1**



**Fig.2**

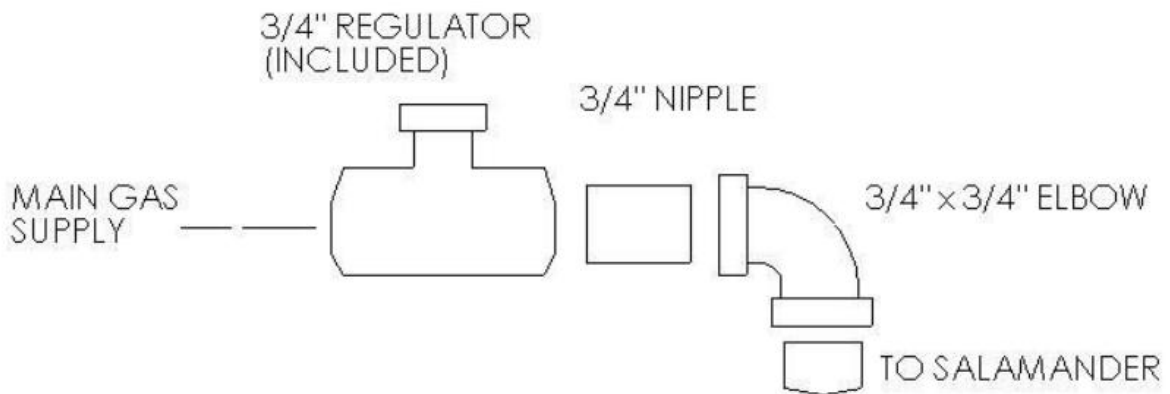

**Fig.3**

The minimum supply pressure (upstream of the regulator) should be 7-9" W .C. for natural gas and 11 -12" W .C. for propane gas. At no time should the regulator be connected to supply pressure greater than ½ psi (3.5 k Pa) or 14" W .C.

### FLUE CONNECTIONS

**DO NOT** obstruct the flow of flue gases from the flue located on the rear of the broiler. It is recommended that the flue gases be ventilated to the outside of the building through a ventilation system installed by qualified personnel.

Information on the construction and installation of ventilating hoods may be obtained from the standard for "Vapor Removal from Cooking Equipment," NFPA No. 96 (latest edition), available from the National Fire Protection Association, Batterymarch Park, Quincy, MA02269.

## WALL MOUNTING OF SALAMANDER

For Salamander Broiler to be mounted on a Wall (Fig.4).

The separate wall mounting bracket accessory will be needed to wall mount the unit.

1. Place mounting bracket (balloon 3) and screws provided.
2. Place leveling Screws (balloon 1) into Salamander.
3. Place wall bracket (balloon 2) on the wall where you want the Salamander.  
(Proper anchoring needed at least 50 lbs. support per anchor)
4. Lower Salamander into wall bracket
5. Adjust leveling screws to level Salamander and bring parallel to wall. SALAMANDER MUST BE LEVEL TO OPERATE PROPERLY.

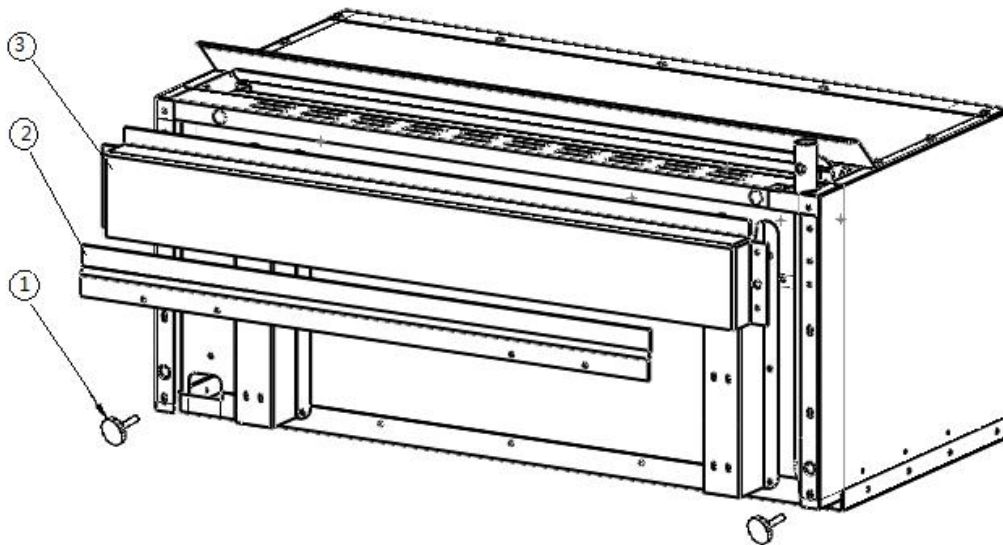

Fig. 4

## MOUNTING OVER GAS RANGE BACK DESIGNED TO MOUNT THIS SALAMANDER BROILER (Fig. 6)

If the Salamander broiler is to be mounted over a gas range WHICH IS DESIGNED SPECIFICALLY TO RECEIVE THIS SALAMANDER BROILER, it must be installed according to the instructions below:

Using the twelve bolts provided (balloon 1), install mounting brackets (balloon 2) on both top mounting posts (balloon 3). See photos below to show how to install posts on range back.

Fig. 6

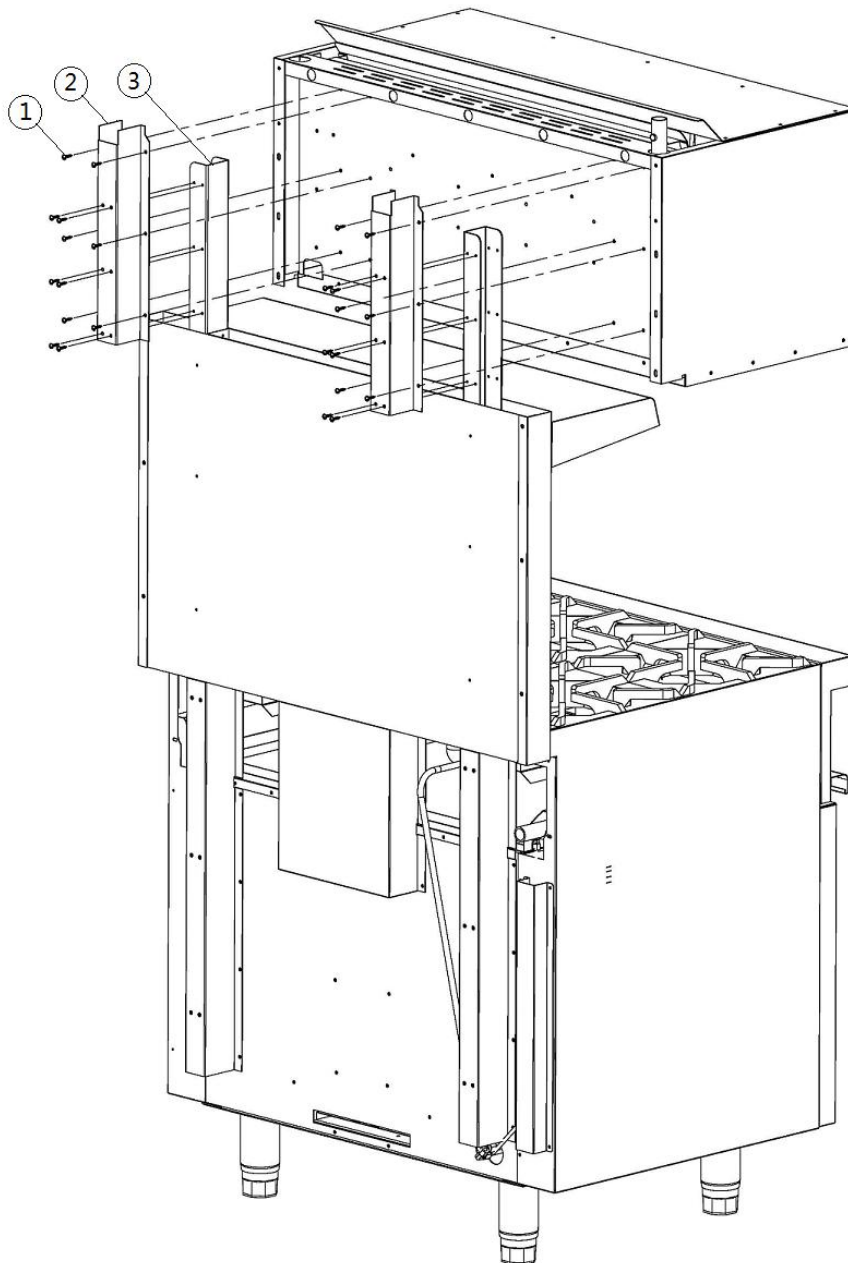



## Salamander Broiler- Range back installation

1. Take off the 12 self-tapping screws on the range back.



2. Insert the Salamander support column into the Range back plate as shown and tighten it with screws







3. Lift Salamander and attach it to the proper position of the support column



4. Take two brackets out of the package



5. Attach Salamander mounting track to the appropriate screw according to the hole position and tighten all



screws



# OPERATION

**WARNING:** THE SALAMANDER BROILER AND ITS PARTS ARE HOT. BE CAREFUL WHEN OPERATING, CLEANING OR SERVICING THE BROILER.

## CONTROLS

**Angled Handle** —Elevates or lowers the broiling drawer and grate to different positions. Grasp the handle and pull towards broiler cavity. This releases the mechanism and allows the lifting handle to move into the desired position.

**Burner Valve** — Regulate the flow of gas to the burners. Gas flow is increased by turning the valve counterclockwise.

**Drip Tray** —Collects grease and waste which is diverted by the drip shield. DO NOT allow the drip tray to overflow. Empty the drip tray when three-quarters full to reduce the possibility of spillage.

**Drawer Handle** —Pull the drawer out for loading and unloading. To operate, pull straight out.

## LIGHTING, RELIGHTING, AND SHUTDOWN INSTRUCTIONS

1. Turn burner valve to the OFF position and wait 5 minutes.
2. Light the pilot adjacent to the main burner. Adjust the pilot valve screw until the pilot flame has a slight yellow tip.
3. After the pilot has been established, turn the burner valve to the ON position.
4. If the burners fail to light, turn off all valves, wait 5 minutes and repeat steps 1 -3.
5. To shut down, turn the burner valve to the OFF position.

## RACK POSITION AND GAS SETTING

Each operator will find the optimum rack position and gas setting for various products; however, it is recommended that gas input be reduced first when lower rack temperatures are desired. Further reduction in rack temperatures, if necessary, can then be obtained by lowering rack position. Infrared burner must use the full on gas setting.

## CLEANING

1. Allow broiler to cool.
2. To remove broiler rack for cleaning, adjust broiler rack to center position.
3. Position left and right hands simultaneously on edges of broiler rack and raise both rack stops.
4. Slide broiler rack and drip tray forward past rack stops, (which must be pivoted out of the way) holding tray up against racks.
5. Remove broiler rack and drip tray from broiler.
6. Let back of tray drop down to vertical to allow front hooks to disengage.

7. Remove drip pan from broiler rack and clean as you would any normal utensil, using care not to damage the front hooks
8. To replace, hook the drip tray to the broiler rack while tray is in a vertical position.
9. Replace broiler rack and drip tray in side channels while holding tray up close to rack.
10. Clean bottom pan. Slide pan out and wash with soap and water. Rinse thoroughly and wipe dry with a soft clean cloth.
11. Clean stainless steel surfaces with a mild detergent and water, using a damp cloth, or with a commercial stainless steel cleaner. Rinse thoroughly and wipe dry with a soft clean cloth.
12. Burner ports and throats should be thoroughly cleaned. Venturi must be free from grease and lint. **DO NOT** insert tooth pick or any sharp object in burner port holes.

## **MAINTENANCE**

**WARNING:** THE BROILER AND ITS PARTS ARE HOT. BE CAREFUL WHEN OPERATING, CLEANING, OR SERVICING THE SLAMANDER BROILER.

### **LUBRICATION**

Burner valve stems must be lubricated. Upon sticking, a burner valve stem should receive maintenance from your local authorized servicer.

### **PILOT LIGHTS**

Pilot lights are to be kept clean and adjusted at the proper flame height.

### **VENT**

Annually, when the broiler is cool, check the flue and clear any obstructions.

### **SERVICE AND PARTS INFORMATION**

Contact your local Service Agency to obtain service and parts information.

# PARTS

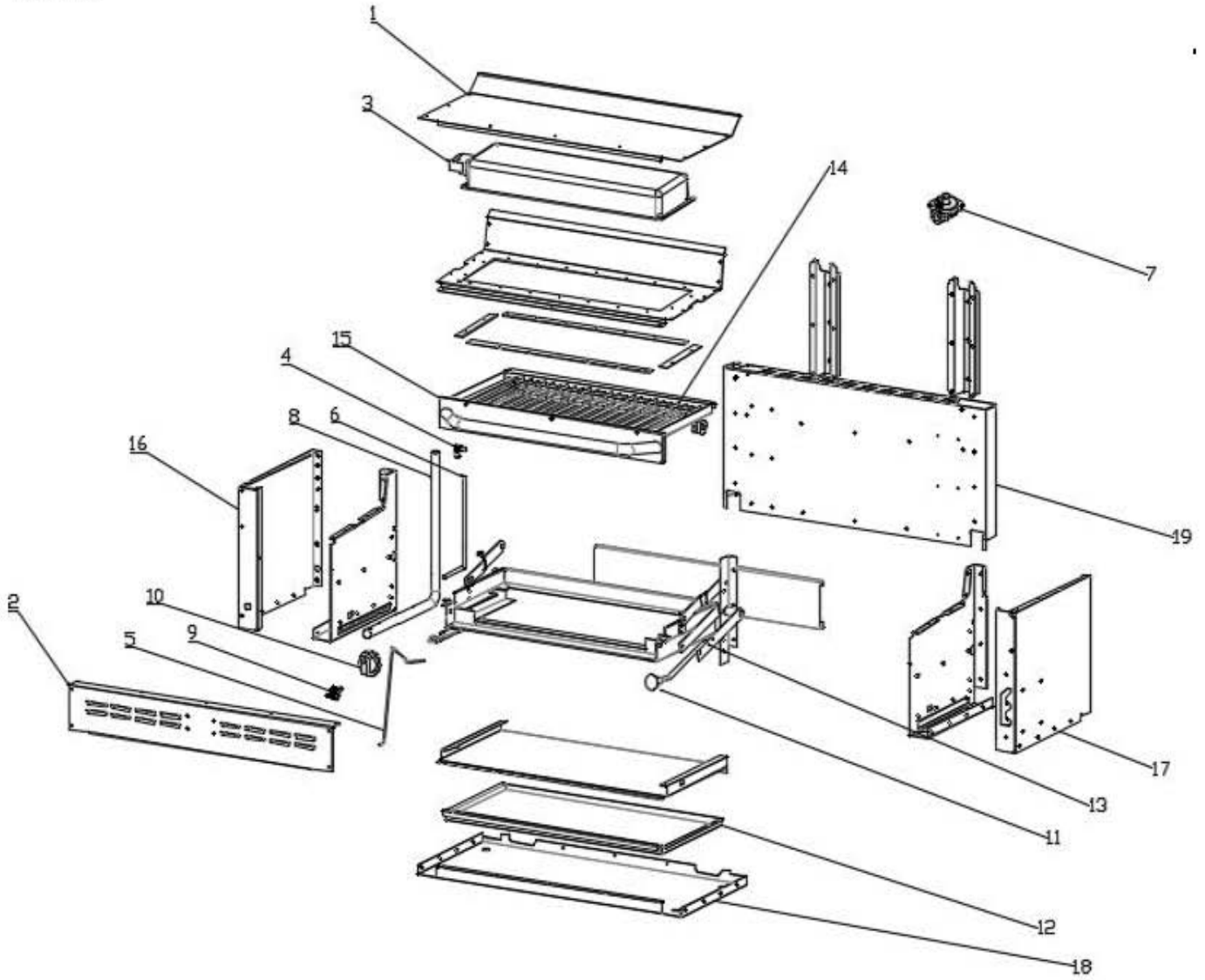

12	Drip pan	1			
11	Shelf knob FS	1			
10	Knob FS	1			
9	Gas valve FS	1			
8	Main gas manifold	1			
7	Regulator FS	1	19	Rear panel	1
6	Burner gas tube assy	1	18	Bottom panel	1
5	Pilot gas tube	1	17	Right side panel	2
4	Orifice: Natural #31 LP #52	1	16	Left side panel	2
3	Burner FS	1	15	Drawer	1
2	Front vent panel	1	14	Wire grill FS	1
1	Top cover	1	13	Shelf mechanism assy	1
NO.	PART	QTY	NO.	PART	QTY

PART LIST



## Conversion to LP gas orifice

1. Take out the screws on the top cover, then take off the top cover. You can see the orifice is on the left side of the salamander as below **Fig.7** shows.



**Fig.7**

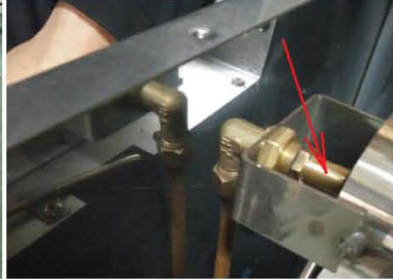

**Fig.8**

2. As Fig. 8 shows, unscrew and remove the Nat. gas orifice [#31( $\phi$ 3.2mm)] turning counter-clockwise, then screw in the LP gas orifice [#52( $\phi$ 1.68mm)] clockwise.
3. Change the pressure regulator spring kit to LP gas model, set at 10" W .C. (Water Column).



**Fig.9,**



**Fig.10**

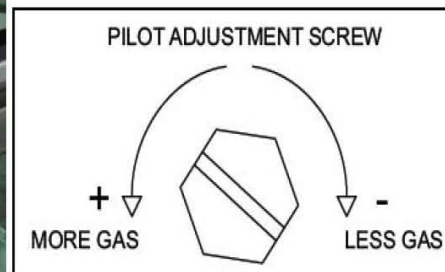

4. Turn pilot adjustment screw clockwise, then light standing pilot and adjust flame to be 1/4" high.

A product with the name incorporates the best in durability and low maintenance. We all recognize, however, that replacement parts and occasional professional service may be necessary to extend the useful life of this unit. When service is needed, contact a Authorized Service Agency, or your dealer. To avoid confusion, always refer to the model number, serial number, and type of your unit.





**LIMITED ORIGINAL COMMERCIAL EQUIPMENT WARRANTY  
FOR THE FLM-SM36 SERIES GAS SALAMANDER BROILER**

**FLAMASTER warrants the FLM-SM36 Gas Salamander broiler to be free of defects in materials and workmanship for a period of 1 year from the date of original installation.**

**This Warranty is subject to the following conditions and limitations:**

- 1. This warranty is limited to product(s) sold by FLAMASTER to the original user in the continental United States and Canada.**
- 2. Original installation must occur within 18 months of date of manufacture, and proof of the installation must be provided to FLAMASTER.**
- 3. The liability of FLAMASTER is limited to the repair or replacement of any part found to be defective.**
- 4. FLAMASTER will bear normal labor charges incurred in the repair or replacement of a warranted piece of equipment within 50 miles (80 kilometers) of an authorized service agency. Time and travel charges in excess of 50 miles (80 kilometers) will be the responsibility of the person or firm requesting the service.**
- 5. This warranty does not apply to any product(s) which have not been installed in accordance with the directions published in the appropriate installation and operation manuals. FLAMASTER will bear no responsibility or liability for any product(s) which have been mishandled, abused, misapplied, misused, subject to harsh chemical action, (chlorinated or sulfate products), or poor water quality, field modified by unauthorized personnel, damaged by flood, fire, or other acts of nature, or which have altered or missing serial numbers.**
- 6 FLAMASTER does not recommend or authorize the use of any product(s) in a non-commercial application, including but not limited to residential use. The use or installation of product(s) in non-commercial applications renders all warranties, expressed or implied, including the warranties of MERCHANTABILITY and FITNESS FOR A PARTICULAR PURPOSE, null and void, including any responsibility for damage, cost and legal actions resulting from the use or installation of product(s) in any non-commercial setting.**
- 7. Adjustments such as calibrations, leveling, tightening of fasteners or utility connections normally associated with original installation are the responsibility of the installer and not that of FLAMASTER.**
- 8. Exception to the 1 year warranty period is as listed:**

**Fry Tanks:**

**If tank is found to be leaking within the first year of operation from date of installation and verified by an authorized service agency, the entire CP-F-Salamander broiler will be replaced. Replacement Salamander broiler will be warranted for the balance of the original warranty.**

**Original purchased replacement parts manufactured by FLAMASTER will be warranted for 90 days from the parts invoice date. This warranty is for parts cost only, and does not include freight or labor charges. Exceptions are stainless steel fry tanks which will be warranted as stated in item 8.**

**9. This states the exclusive remedy against FLAMASTER relating to the product(s), whether in contract or in tort or under any other legal theory, and whether arising out of warranties, representations, instructions, installations or defects from any cause. FLAMASTER shall not be liable, under any legal theory, for loss of use, revenue or profit, or for substituted use or performance, or for incidental, indirect, or special or consequential damages or for any other loss of cost of similar type.**

**10. THIS WARRANTY AND THE LIABILITIES SET FORTH HEREIN ARE EXCLUSIVE AND IN LIEU OF ALL OF THEIR LIABILITIES AND WARRANTIES, EXPRESSED OR IMPLIED, INCLUDING BUT NOT LIMITED TO, IMPLIED WARRANTIES OR MERCHANTABILITY AND FITNESS FOR PARTICULAR PURPOSE AND CONSTITUTES THE ONLY WARRANTY OF FLAMASTER WITH RESPECT TO THE PRODUCT(S).**