

Flamaster

www.flamasterusa.com

Project name : _____

Location : _____

Item# : _____ QTY : _____

Model# : _____

Electric Steam Table

Model: FLM-ST2-SS



- **Stainless Steel Construction:** Ensures durability and reliability.
- **Die-Stamped Stainless Steel Wells:** Features a 12" x 20" opening with a raised lip design for spill containment and easy cleaning. Includes an 8" wide white poly cutting board to facilitate smooth prep and pan handling.
- **Fully Insulated Wells:** All four sides and bottom are insulated with fiberglass. Features 8" deep, dry heating wells that hold two full-size food pans. Accommodates various pan configurations for maximum versatility.
- **Independent Infinite Controls:** Each 120V/500W well is individually controlled for optimum heating versatility.
- **Versatile Dry/Wet Operation:** Although intended for dry use, this steam table can be converted for wet use with a compatible spillage pan (sold separately).
- **Safety & Sanitation:** Meets cETLus electrical safety standards and ETL Sanitation hygiene requirements.

Toll Free: +1(800)373-8699
flamaster@chefmindgroup.com
Address: 1189S Jellick Ave,
City of Industry, CA 91748



Electric Steam Table

Model: FLM-ST2-SS

•ETL Certified For Safety & Sanitation

MODEL	VOLTS	WATTS	AMPS	PLUG	OVERALL DIMENSIONS	NET WEIGHT	SHIPPING DIMENSIONS	SHIPPING WEIGHT
FLM-ST2-SS	120V	1,000	8.33	5-20P	30 X 30½ X 34½	84 lbs.(38kg)	33¾ X 25½ X 20½	93 lbs.(42kg)

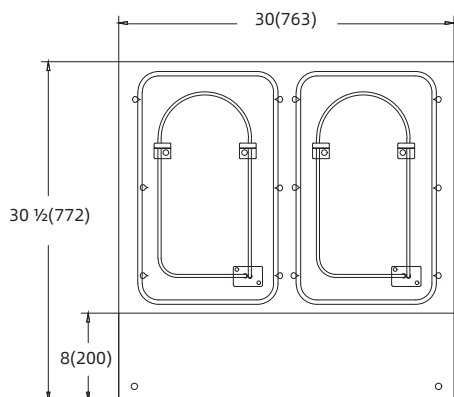
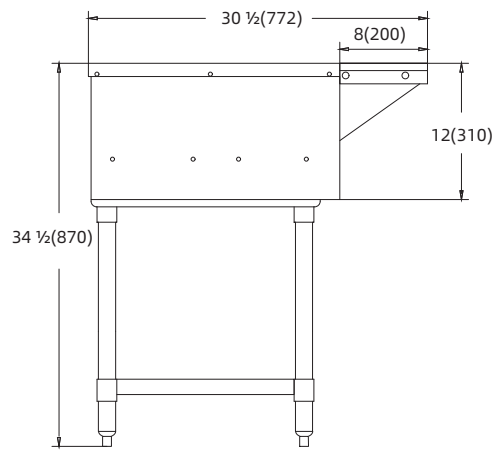
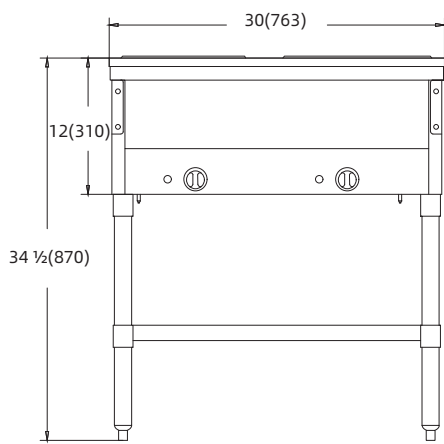

1 YEAR PARTS WARRANTY (NOT FOR RESIDENTIAL USE)



CHEFMIND GROUP INC.

SPECIFICATIONS SUBJECT TO CHANGE WITHOUT NOTICE