

Flamaster

www.flamasterusa.com

Project name: _____

Location: _____

Item#: _____ QTY: _____

Model#: _____

Wok Range

Model: FLM-WOK16-NG



- Jet burner with an "L" shaped adjustable gas valve.
- Anti-clogging 28 tip jet burner, at 125,000 BTU (37 KW).
- Intense cone shaped heat.
- Stainless steel front side and cabinet base.
- Pilot ignition system.
- 16" (406 mm) wok top sizes available.
- This appliance is manufactured for commercial installation only, not intended for home use.
- 3/4" NPT rear gas connections. Supply gas pressure not to exceed 14" W.C. (1/2 PSI)
Natural gas operating pressure - 5.0" W.C.
Recommended supply pressure 7-9" W.C.
Propane gas operating pressure - 10.0" W.C.
Recommended supply pressure 11-12" W.C..
- A gas pressure regulator supplied with unit must be installed.
- An adequate ventilation system is required for Commercial Cooking Equipment..
- Require a 6" clearance at both side and rear adjacent to combustible construction.
- ETL design certified NSF listed.

Toll Free: +1(800)373-8699
flamaster@chefmindgroup.com
Address: 1189S Jellick Ave,
City of Industry, CA 91748



Wok Range

Model: FLM-WOK16-NG

•ETL Design Certified, NSF Listed

MODEL	GAS/TYPE	TOTAL BTU	OVERALL DIMENSIONS	NET WEIGHT	SHIPPING DIMENSIONS	Shipping Weight
FLM-WOK16-NG	Natural Gas	125,000	17½ X 24½ X 35½	68 lbs.(31kg)	18¼ X 22½ X 25½	84 lbs.(38 kg)

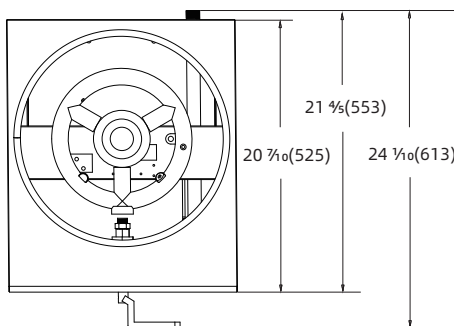
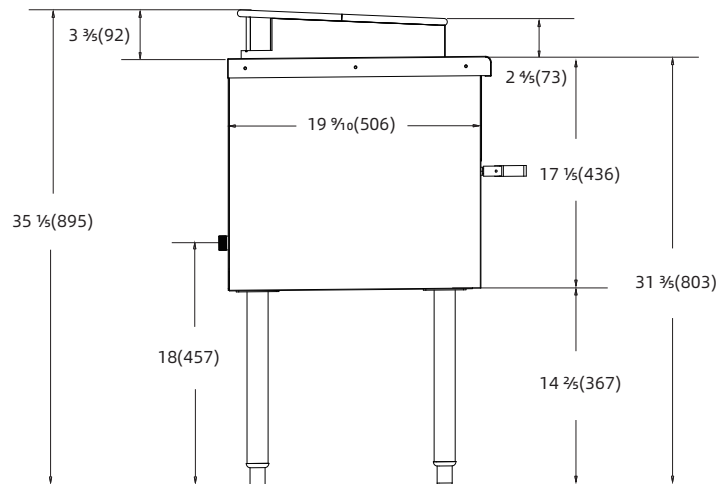
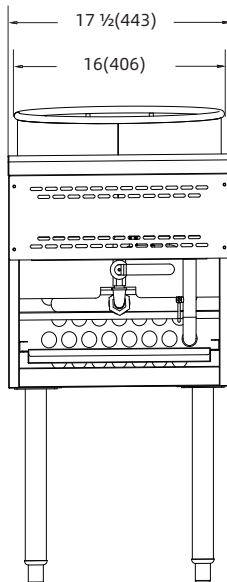

1 YEAR PARTS WARRANTY (NOT FOR RESIDENTIAL USE)



CHEFMIND GROUP INC.

SPECIFICATIONS SUBJECT TO CHANGE WITHOUT NOTICE