

ChefAsst

www.chefasstusa.com

Project name : _____

Location : _____

Item# : _____ QTY : _____

Model# : _____

Automatic Meat Slicer

Model: HB-350



- All contacting food parts are made of material that meets food safety and hygiene standards.
- Made of Italian chrome-vanadium alloy, the high-quality blades are durable and sharp.
- The blade is made of special steel, polished and chrome-plated.
- The adjustable thickness knob allows slice thickness to be precisely adjusted from 0.2mm to 20mm, ensuring uniform thickness.
- The carriage speed is adjustable.
- Four operation switches.
- The machine is equipped with professional anti-slip feet to ensure stability and prevent any shaking during use.
- Each machine comes with a grinding stone, which is simple, convenient and easy to operate.

Toll Free: +1 (800) 373-8699

Info@chefmindgroup.com

Address: 1189S Jellick Ave,
City of Industry, CA 91748



ChefAsst

www.chefasstusa.com

Toll Free: +1 (800) 373-8699

Info@chefmindgroup.com

Address: 1189S Jellick Ave,
City of Industry, CA 91748

Automatic Meat Slicer

Model: HB-350

•ETL Certified For Safety & Sanitation



MODEL	VOLTS	HERTZ	PHASE	POWER	BLADE SIZE	NEMA PLUG	NET WEIGHT	GROSS WEIGHT	SHIPPING DIMENSIONS
HB-350	110V	60Hz	1PH	750W×2	14 1/2"	5-15P	474 lbs	581 lbs	44 1/10" × 32 9/10" × 65"

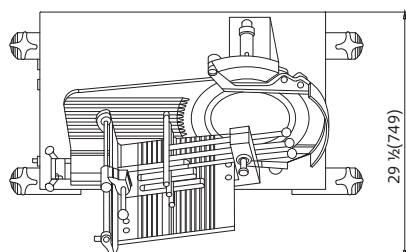
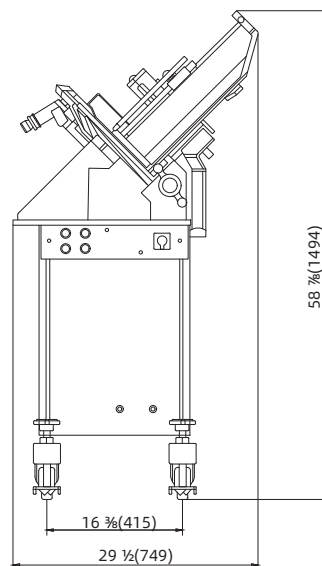
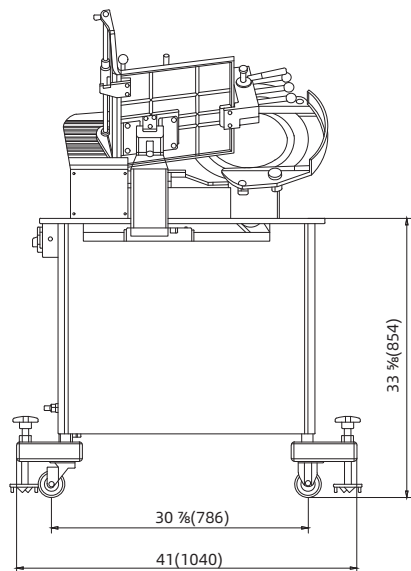

1 YEAR PARTS WARRANTY (NOT FOR RESIDENTIAL USE)



CHEFMIND GROUP INC.

SPECIFICATIONS SUBJECT TO CHANGE WITHOUT NOTICE