

Meat Slicer

Model: HBS-250A



- *Classic meat slicer with plastic legs and handle. Its anodized aluminum-magnesium alloy body ensures food-contact parts are safe and easy to clean.*
- *The razor sharp 10 inch stainless steel blade, featuring an adjustable thickness knob, cuts slices up to 1/2 inch thick and is rated for 2 hours of use daily.*
- *The easy to use built-in sharpener ensures your blade stays like new, and the manual feed carriage glides smoothly for easy operation and is removable for cleaning.*

Toll Free: +1 (800) 373-8699
Info@chefmindgroup.com
Address: 1189S Jellick Ave,
City of Industry, CA 91748



Meat Slicer

Model: HBS-250A

•ETL Certified For Safety & Sanitation

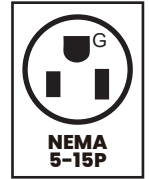

| MODEL | VOLTS | HERTZ | PHASE | POWER | BLADE SIZE | NEMA PLUG | NET WEIGHT | GROSS WEIGHT | SHIPPING DIMENSIONS |
|----------|-------|-------|-------|-------|------------|-----------|------------|--------------|-------------------------------|
| HBS-250A | 110V | 60Hz | 1PH | 150W | 10" | 5-15P | 34 lbs | 39 lbs | 22 3/8" x 18 3/10" x 16 3/10" |

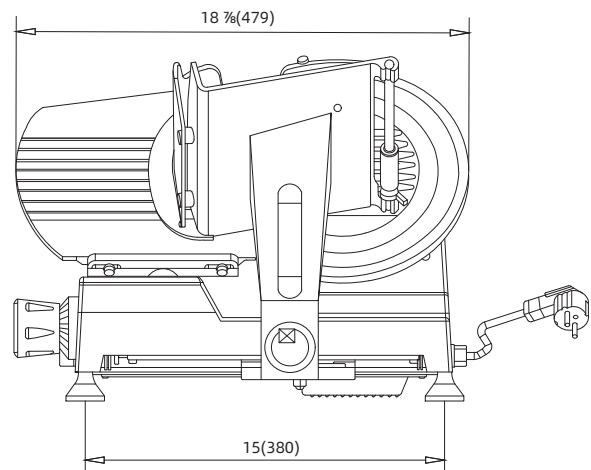
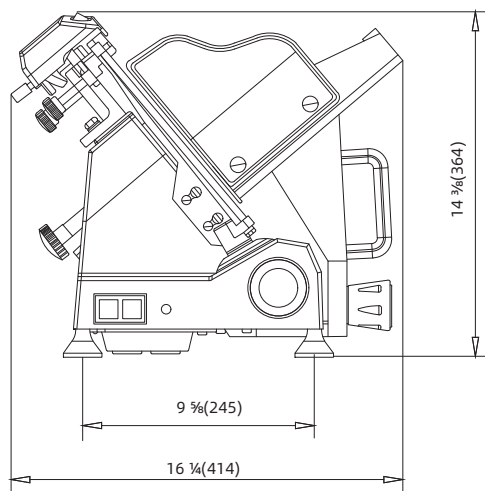

1 YEAR PARTS WARRANTY (NOT FOR RESIDENTIAL USE)

