

Meat Slicer

Model: HBS-300A



- *Classic meat slicer with plastic legs and handle. Its anodized aluminum-magnesium alloy body ensures food-contact parts are safe and easy to clean.*
- *The razor sharp 12 inch stainless steel blade, featuring an adjustable thickness knob, cuts slices up to 3/5 inch thick and is rated for 2 hours of use daily.*
- *The easy to use built-in sharpener ensures your blade stays like new, and the manual feed carriage glides smoothly for easy operation and is removable for cleaning.*

Toll Free: +1 (800) 373-8699
Info@chefmindgroup.com
Address: 1189S Jellick Ave,
City of Industry, CA 91748



Meat Slicer

Model: HBS-300A

•ETL Certified For Safety & Sanitation

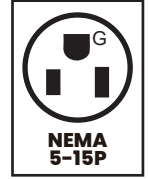

MODEL	VOLTS	HERTZ	PHASE	POWER	BLADE SIZE	NEMA PLUG	NET WEIGHT	GROSS WEIGHT	SHIPPING DIMENSIONS
HBS-300A	110V	60Hz	1PH	250W	12"	5-15P	49 lbs	54 lbs	24 3/10" x 22 1/10" x 20 1/10"

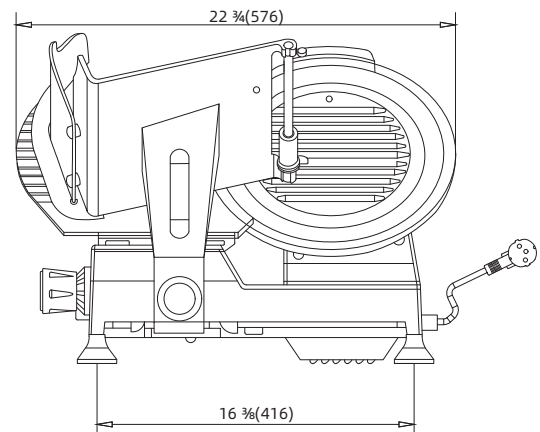
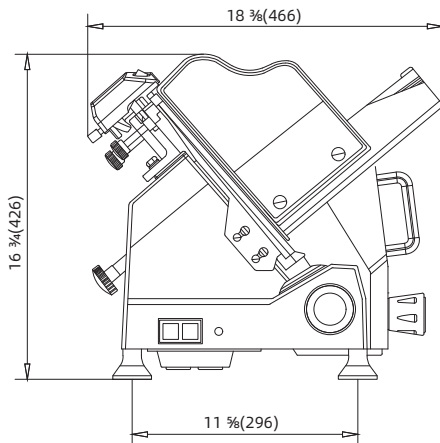

1 YEAR PARTS WARRANTY (NOT FOR RESIDENTIAL USE)

