

## 65" Blade Countertop Vertical Band Meat Saw

### Model: HLS-1650A



- *The premium aluminum-magnesium alloy body is rust-proof, easy to clean, and designed for commercial use.*
- *Equipped with a blade guard and stabilizer to ensure operational safety and blade stability.*
- *Effortlessly cuts through various bones, pork trotters, beef steaks, frozen meat, and frozen fish.*
- *The multifunctional sliding feed platform ensures smooth and stable material feeding.*
- *A high-power motor delivers stable, shake-free operation without stalling.*

# ChefAsst

www.chefasstusa.com

Toll Free: +1 (800) 373-8699

Info@chefmindgroup.com

Address: 1189S Jellick Ave,  
City of Industry, CA 91748

## 65" Blade Countertop Vertical Band Meat Saw

### Model: HLS-1650A

**•ETL Certified For Safety & Sanitation**



MODEL	VOLTS	HERTZ	PHASE	POWER	WHEEL DIAMETER	SAW LENGTH	NEMA PLUG	NET WEIGHT	GROSS WEIGHT	SHIPPING DIMENSIONS
HLS-1650A	110V	60Hz	1PH	750W	8 3/8"	65"	5-15P	80 lbs	116 lbs	21 7/10" x 20 1/2" x 40 1/8"

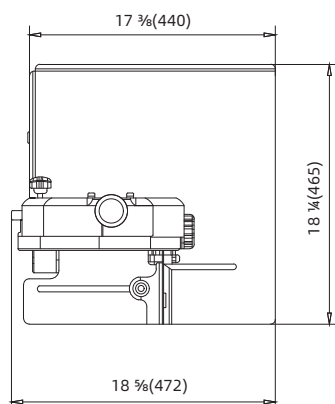
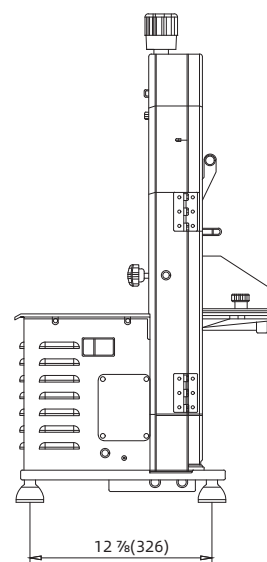
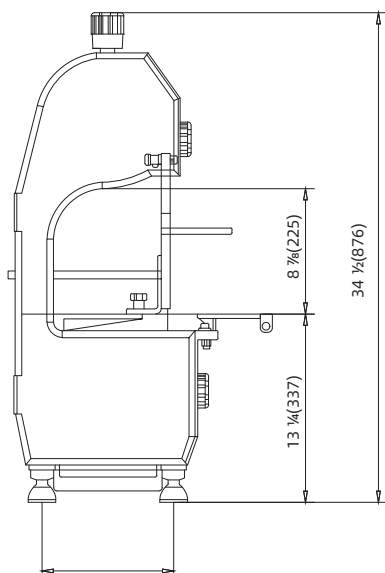

**1 YEAR PARTS WARRANTY (NOT FOR RESIDENTIAL USE)**



**CHEFMIND GROUP INC.**

SPECIFICATIONS SUBJECT TO CHANGE WITHOUT NOTICE