

75" Blade Countertop Vertical Band Meat Saw

Model: HLS-1900A



- *The premium aluminum-magnesium alloy body is rust-proof, easy to clean, and designed for commercial use.*
- *Equipped with a blade guard and stabilizer to ensure operational safety and blade stability.*
- *Effortlessly cuts through various bones, pork trotters, beef steaks, frozen meat, and frozen fish.*
- *The multifunctional sliding feed platform ensures smooth and stable material feeding.*
- *A high-power motor delivers stable, shake-free operation without stalling.*

Toll Free: +1 (800) 373-8699
Info@chefmindgroup.com
Address: 1189S Jellick Ave,
City of Industry, CA 91748



ChefAsst

www.chefasstusa.com

Toll Free: +1 (800) 373-8699

Info@chefmindgroup.com

Address: 1189S Jellick Ave,
City of Industry, CA 91748

75" Blade Countertop Vertical Band Meat Saw

Model: HLS-1900A

•ETL Certified For Safety & Sanitation

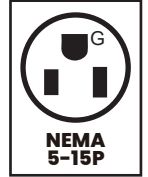

MODEL	VOLTS	HERTZ	PHASE	POWER	WHEEL DIAMETER	SAW LENGTH	NEMA PLUG	NET WEIGHT	GROSS WEIGHT	SHIPPING DIMENSIONS
HLS-1900A	110V	60Hz	1PH	750W	9"	75"	5-15P	80 lbs	116 lbs	25 3/8" x 24 1/8" x 45 3/8"

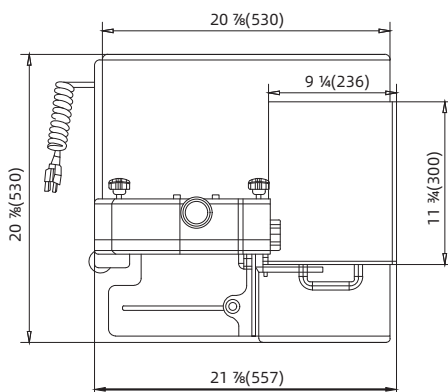
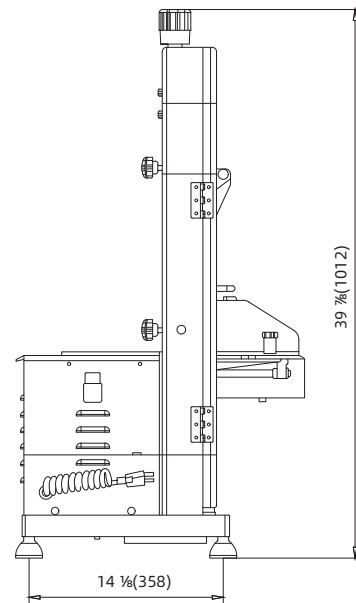
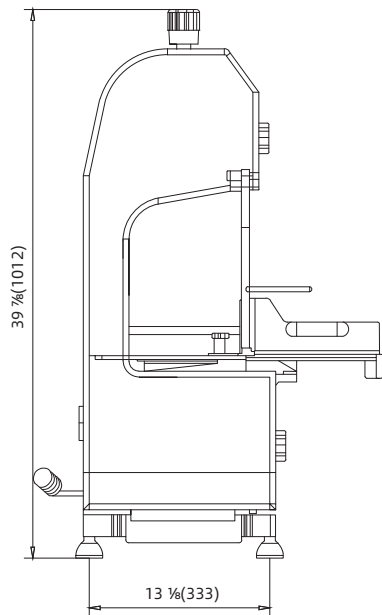

1 YEAR PARTS WARRANTY (NOT FOR RESIDENTIAL USE)



CHEFMIND GROUP INC.

SPECIFICATIONS SUBJECT TO CHANGE WITHOUT NOTICE