

80" Blade Floor Model Vertical Band Meat Saw

Model: HLS-2020



- *This commercial bone saw machine features a premium stainless steel body that is rust-proof, easy to clean, and designed for commercial use.*
- *The saw blade protection stabilizer safeguards the blade from damage while maintaining stability during operation.*
- *Effortlessly cuts through various bones, pork trotters, beef steaks, frozen meat, and frozen fish.*
- *The multifunctional sliding feed platform ensures smooth and stable material feeding.*
- *A high-power motor delivers stable, shake-free operation without stalling.*
- *Features a 304 stainless steel pulley that is wear-resistant, deformation-proof, and leaves no black residue on meat or bones.*

80" Blade Floor Model Vertical Band Meat Saw

Model: HLS-2020

•ETL Certified For Safety & Sanitation



MODEL	VOLTS	HERTZ	PHASE	POWER	WHEEL DIAMETER	SAW LENGTH	NEMA PLUG	NET WEIGHT	GROSS WEIGHT	SHIPPING DIMENSIONS
HLS-2020	110V	60Hz	1PH	1500W	9 9/16"	79 1/2"	5-15P	265 lbs	341 lbs	29 3/10" x 26 3/5" x 63"

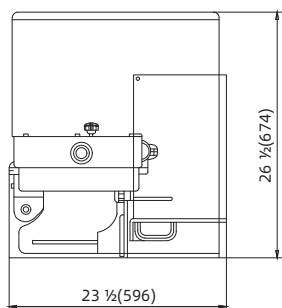
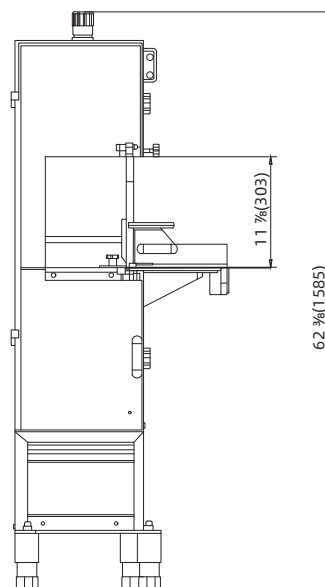
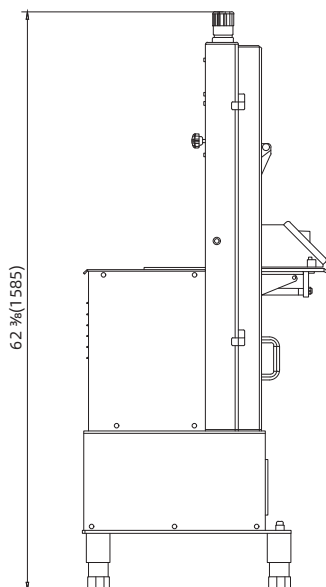

1 YEAR PARTS WARRANTY (NOT FOR RESIDENTIAL USE)

