

## Meat Grinder

### Model: HM-12



- Aluminum-magnesium alloy body with stainless steel tray.

- This machine integrates functions such as meat grinding, vegetable chopping, and sausage filling.

- The discharge hole has no gaps, does not accumulate dirt, is easy to disassemble, and is convenient for cleaning.

- The high-performance auger retains the nutrients in the food and keeps the meat fresh.

- One-touch safety switch: waterproof and leakage-proof, safe with long service life.

- Comfortable anti-slip foot mats that not only provide good grip during operation but also reduce noise.

# Meat Grinder

## Model: HM-12

**•ETL Certified For Safety & Sanitation**

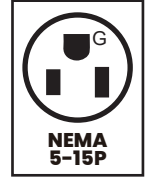

MODEL	VOLTS	HERTZ	PHASE	POWER	NEMA PLUG	NET WEIGHT	GROSS WEIGHT	SHIPPING DIMENSIONS
HM-12	110V	60Hz	1PH	850W	5-15P	32 lbs	34 lbs	23 1/2" x 10 3/8" x 17 3/16"

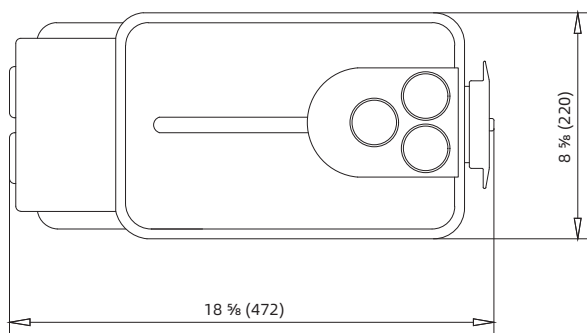
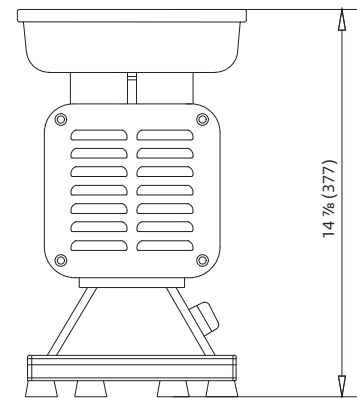
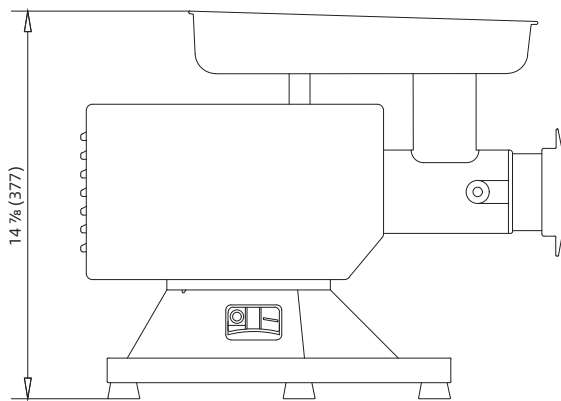

**1 YEAR PARTS WARRANTY (NOT FOR RESIDENTIAL USE)**

