

Meat Grinder

Model: HM-12N



- Aluminum-magnesium alloy body with stainless steel tray.
- This machine integrates functions such as meat grinding, vegetable chopping, and sausage filling.
- The discharge hole has no gaps, does not accumulate dirt, is easy to disassemble, and is convenient for cleaning.
- The high-performance auger retains the nutrients in the food and keeps the meat fresh.
- One-touch safety switch: waterproof and leakage-proof, safe with long service life.
- Comfortable anti-slip foot mats that not only provide good grip during operation but also reduce noise.

Meat Grinder

Model: HM-12N

•ETL Certified For Safety & Sanitation

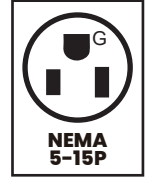

MODEL	VOLTS	HERTZ	PHASE	POWER	NEMA PLUG	NET WEIGHT	GROSS WEIGHT	SHIPPING DIMENSIONS
HM-12N	110V	60Hz	1PH	850W	5-15P	45 lbs	48 lbs	21 3/10" x 12 3/5" x 16"

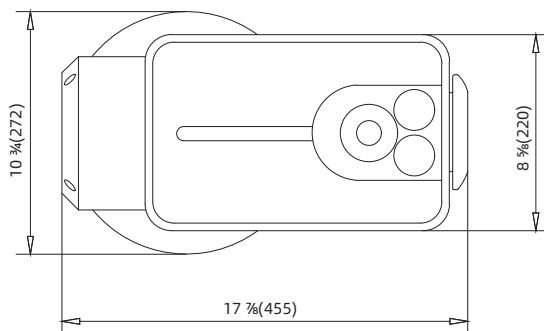
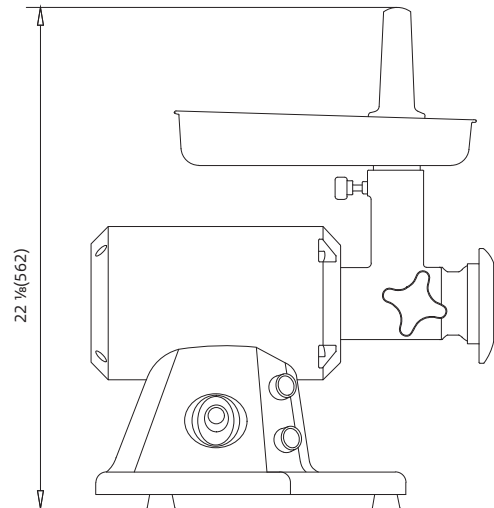
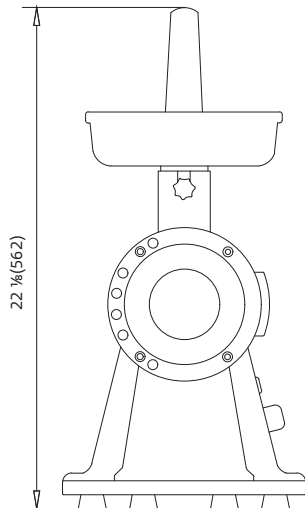

1 YEAR PARTS WARRANTY (NOT FOR RESIDENTIAL USE)

