

48" Curved Glass Refrigerated Bakery Display Case

Model: PLM-371AB



- Tested to NSF Standard 7 requirements for open food storage.
- Sliding Door Design, The design of sliding doors can greatly save space for your store or restaurant.
- Adjustable 3 Glass Shelves, you can adjust in height depending on what you want to display.
- Digital Temperature Control, Our display case uses R290 refrigerant, which keeps the interior temperature at a safe level between 32°F-53.6°F.
- Brilliant Internal LED lighting each shelf and bottom.
- Digital temperature control and display.
- Ventilated cooling system.
- Automatic Defrost.
- Front flat glass.
- Options Air duct outside the glass to remove condensation water.
- Easy to mount casters (2 lockable) are standard with all units.

Toll Free: +1 (800) 373-8699
polarman@chefmindgroup.com
Address: 1189S Jellick Ave,
City of Industry, CA 91748



48" Curved Glass Refrigerated Bakery Display Case

Model: PLM-371AB

•ETL Certified For Safety & Sanitation

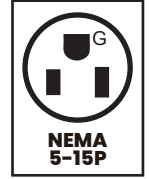

MODEL	EXTERNAL DIMENSION (inches)	V/Hz/Ph	STORAGE CAPACITY L	DOORS	TEMPERATURE	REFRIGERANT	AMPS	SHELVES	NEMA PLUG	SHIPPING WEIGHT (lbs.)
PLM-371AB	48 1/8 x 26 7/8 x 55 1/8	115/60/1	420	2	32°F to 53.6°F	R290	6.7	3	5-15P	525

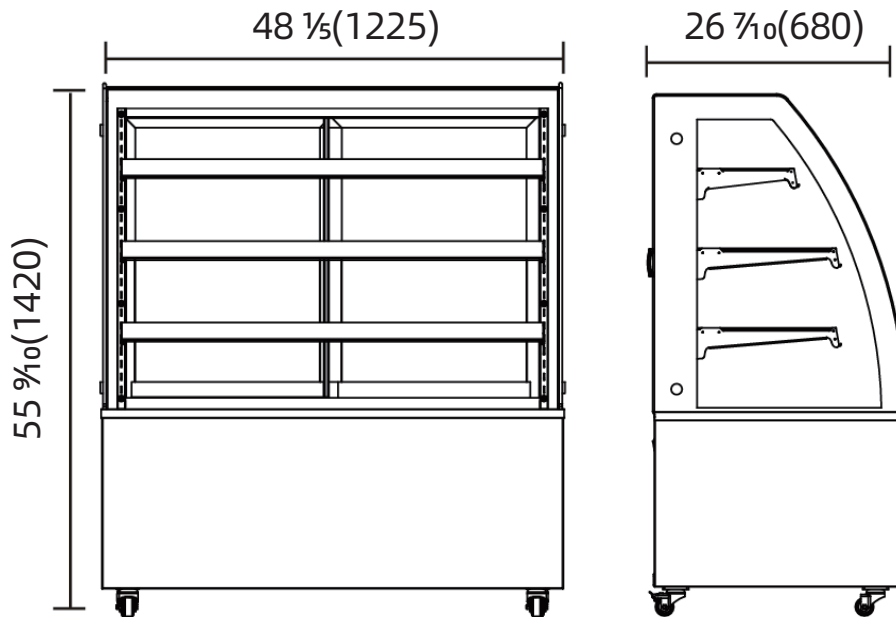

1 YEAR PARTS WARRANTY (NOT FOR RESIDENTIAL USE)

