

74" Chef Base with 2 Drawers

Model: PLM-CBR72



- Tested to NSF Standard 7 requirements for open food storage.
- Stainless steel drawer facings, linings and frames.
- Exterior cabinet construction consists of full stainless front, sides and top.
- Full extension drawers allow for loading and unloading of pans without tipping them.
- Each drawer is equipped with s/s hooked adapter bars and magnetic gaskets that are removable for cleaning.
- Top and bottom drawers hold up to 6" deep pans. Pans are by others*.
- Heavy duty Fulterer telescoping cartridge drawer system.
- Electronic thermostat with external digital LED display for accurate control and easy reading.
- Heavy duty stainless top is insulated with ceramic fabric layer over the foam to prohibit heat transfer to interior cabinet.
- Top comes with standard marine edge on all sides and has a 1" (2" overall) extension on each side to allow cooking equipment to sit flat.
- Self contained capillary tube system using environmentally friendly R290 Hydrocarbon gas.
- Easy to mount plate casters (2 lockable) are standard with all units.

Toll Free: +1 (800) 373-8699
polarman@chefmindgroup.com
Address: 1189S Jellick Ave,
City of Industry, CA 91748



74" Chef Base with 2 Drawers

Model: PLM-CBR72

•Certified to ANSI/NSF Standard 7



MODEL	EXTERNAL DIMENSION inch	V/Hz/Ph	STORAGE CAPACITY Cu-ft	Drawers	TEMPERATURE	REFRIGERANT	HP	AMPS	CORD LENGTH	NEMA PLUG	SHIPPING WEIGHT (lbs.)
PLM-CBR72	74 x 31 7/8 x 26	115V/60Hz/1	10.8	4	33°F~41°F	R290	1/3	2.1	8'	5-15P	353

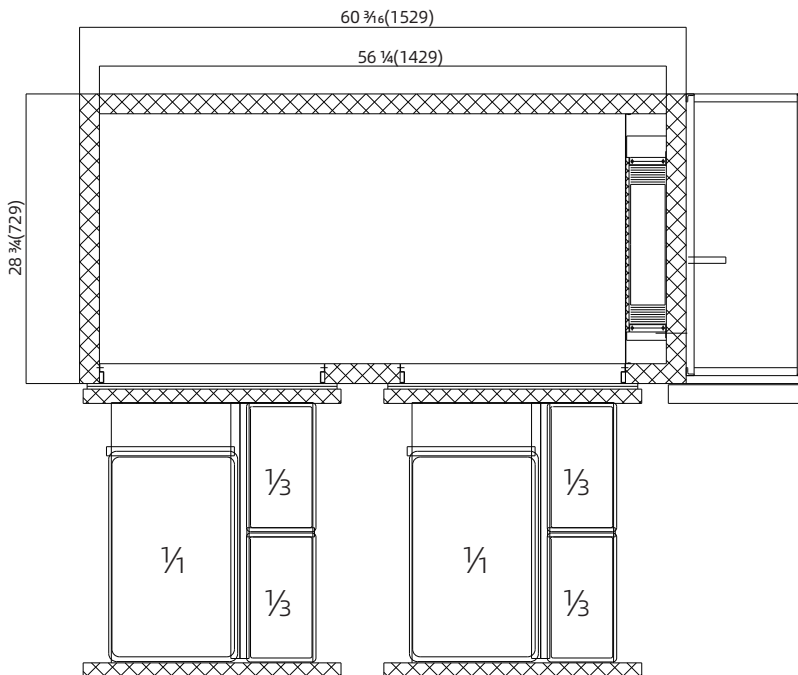
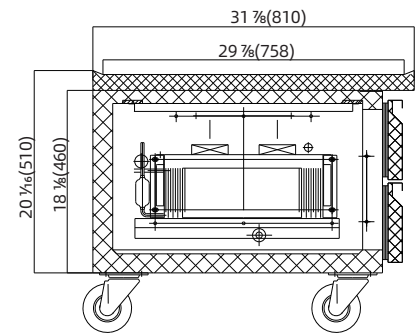
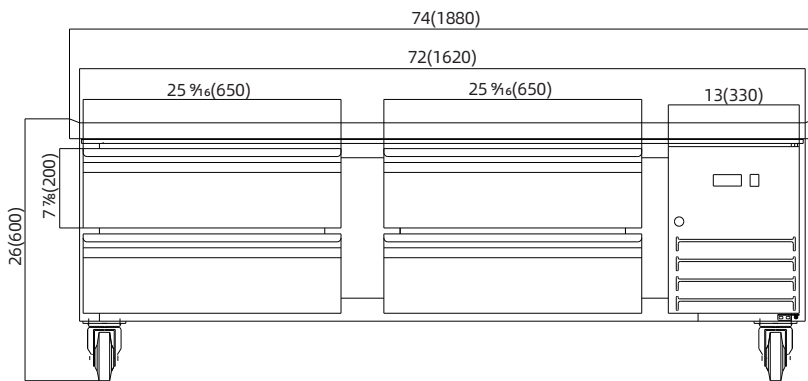

**2 YEAR PARTS WARRANTY
5 YEAR COMPRESSOR WARRANTY**

