

38" Countertop Heated Display Merchandiser

Model: PLM-W102D-M



- Tested to NSF Standard 7 requirements for open food storage.
- Each shelf has its own Independent heat.
- With three-sided glass and an open front for easy access and full visibility.
- Our showcase has 2 chrome plated shelves.
- Equipped temperature controller that ranges from 85 to 190 degrees Fahrenheit.
- Equipped with LED lighting, can better display your food.

Toll Free: +1 (800) 373-8699
polarman@chefmindgroup.com
Address: 1189S Jellick Ave,
City of Industry, CA 91748



Intertek

Intertek

38" Countertop Heated Display Merchandiser

Model: PLM-W102D-M

•ETL Certified For Safety & Sanitation



MODEL	EXTERNAL DIMENSION (inches)	V/Hz/Ph	DISPLAY AREA (m ²)	NET WEIGHT (lbs.)	TEMPERATURE	REFRIGERANT	AMPS	RATED INPUT POWER W	NEMA PLUG	SHIPPING WEIGHT (lbs.)
PLM-W102D-M	37 ½ x 27 ¼ x 27 ½	110/60/1	1.02	108	86°F to 185°F	R290	15	1160	5-15P	115

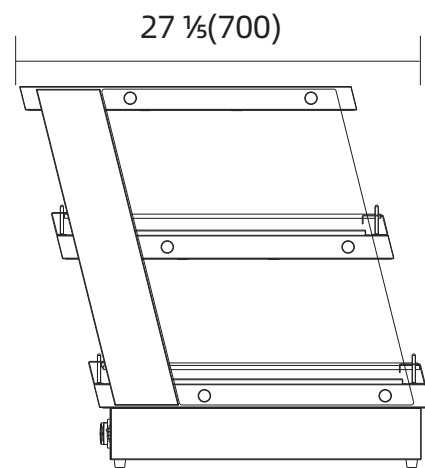
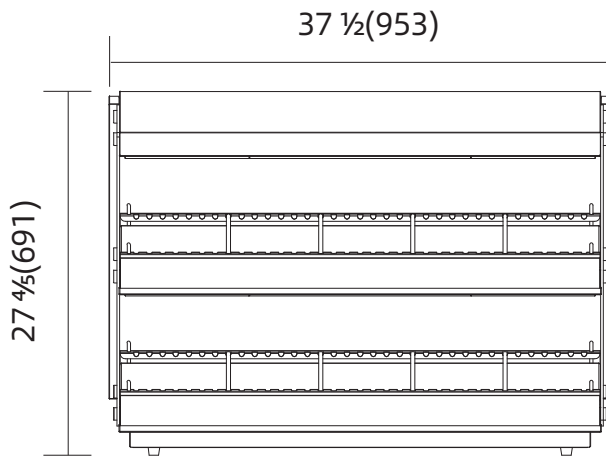

1 YEAR PARTS WARRANTY (NOT FOR RESIDENTIAL USE)

