

31 2/5" Heated Holding / Proofing Cabinet

Model: PLM-W159L-P



- Tested to NSF Standard 7 requirements for open food storage.
- Digital temperature controller and display, uses R-290 refrigerant, which keeps the interior temperature at a safe level between 86°F - 167°F.
- Mechanical Temp Control.
- Mechanical Humidity Control.
- 2 heating ways either by water or air.
- Ventilated heating system.
- 4 Casters, 2 with brakes.
- Insulated Body.

31 2/5" Heated Holding / Proofing Cabinet

Model: PLM-W159L-P

•ETL Certified For Safety & Sanitation



MODEL	EXTERNAL DIMENSION (inches)	V/Hz/Ph	STORAGE CAPACITY L	NET WEIGHT (lbs.)	TEMPERATURE	REFRIGERANT	AMPS	RATED INPUT POWER W	NEMA PLUG	SHIPPING WEIGHT (lbs.)
PLM-W159L-P	31 2/5 x 21 1/10 x 32 2/5	115/60/1	159	125.7	86°F to 167°F	R290	15	1700	5-15P	146

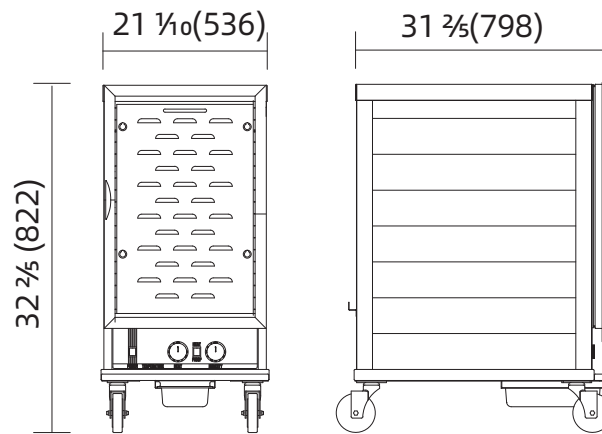

1 YEAR PARTS WARRANTY (NOT FOR RESIDENTIAL USE)



CHEFMIND GROUP INC.

SPECIFICATIONS SUBJECT TO CHANGE WITHOUT NOTICE