

48" Countertop Refrigerated Bakery Display Case

Model: PLM-W202L-5



- *Tested to NSF Standard 7 requirements for open food storage.*
- *Sliding Door Design, The design of sliding doors can greatly save space for your store or restaurant.*
- *Includes 2 Adjustable Shelves*
Our showcase has two chrome wire interior shelves.
- *Digital Temperature Control, Our display case uses R290 refrigerant, which keeps the interior temperature at a safe level between 32°F-53.6°F.*
- *Brilliant Internal LED illumination on top.*
- *Ventilated cooling system.*
- *Automatic Defrost.*
- *Air duct outside the glass to remove condensation water.*

48" Countertop Refrigerated Bakery Display Case

Model: PLM-W202L-5

•ETL Certified For Safety & Sanitation



MODEL	EXTERNAL DIMENSION (inches)	V/Hz/Ph	STORAGE CAPACITY L	DOORS	TEMPERATURE	REFRIGERANT	AMPS	LAMP POWER W	NEMA PLUG	SHIPPING WEIGHT (lbs.)
PLM-W202L-5	48 x 22 2/5 x 27	115/60/1	200	2	32°F to 53.6°F	R290	3.9	2(LED)	5-15P	207

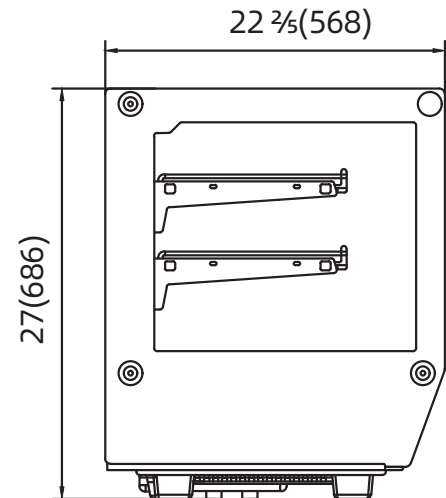
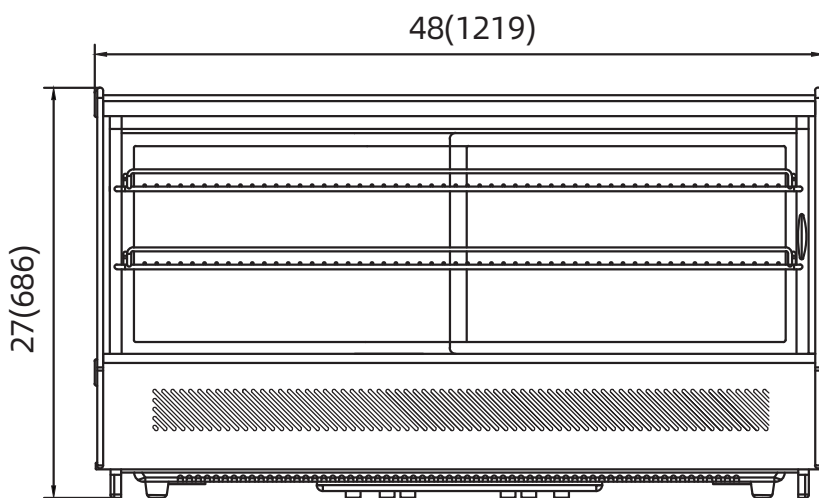

1 YEAR PARTS WARRANTY (NOT FOR RESIDENTIAL USE)



CHEFMIND GROUP INC.

SPECIFICATIONS SUBJECT TO CHANGE WITHOUT NOTICE